

9kg front load washer with 1200 rpm spin speed, UltraMix detergent system, durable ecoinverter motor, Quick 15 minute, Daily 39 minute & Full Wash 60 minute wash programs, 3XL drum opening and time remaining display.



Product Details

FEATURES

Full Wash 60

Our Full Wash 60 lets you wash an entire load of normally soiled items in just 60 minutes without compromising on the wash result.

Daily 39

Quick 15

A quick 15 minute wash for small or delicate loads up to 1.5kg. Ideal for cleaning and refreshing any urgent items you might need.

Add Clothes

With our Pause To Add Clothes function, you can quickly add those forgotten items. It can only be used when the water level is below the door and on programs where the water temperature is less than 60 Celsius.

Hygienic Care option

EcoInverter

The ecoinverter motor delivers quieter operation, improvements in energy efficiency and improved durability, backed by a 10 year parts & labour inverter motor warranty ensuring peace of mind.

Liquid or powder detergent drawer

High spin, less dry time

Delay end option to plan when your wash finishes

BENEFITS

GOODBYE DETERGENT RESIDUES.*

With UltraMix technology, detergent and softener is thoroughly dissolved and activated before it enters the drum. This ensures that your clothes are cleaned without leaving visible detergent residue at the end of the cycle. With UltraMix you can say goodbye to visible detergent residue and forget rewashing*. *Tested on a 3kg mixed load of colour T-shirts and shirts, using recommended powder detergent dosage and load size. Results may vary depending on load size, detergent type and water pressure.

HYGIENIC CLEAN. VAPOUR CARE

Electrolux front load washers with vapour option removes up to 99.2% of Der f1 (dust mite) and Fel d1 (cat allergen) and up to 99.9% of Staphylococcus aureus and Klebsiella pneumonia during a 40C cottons wash.

QUIETLY EFFICIENT

Reduce your energy needs by up to 50% with a powerful and reliable EcoInverter motor that cuts vibrations and noise to the barest whisper. With the 10 year parts and labour inverter motor warranty your Electrolux will deliver, wash after wash, year after year. *vs Electrolux non inverter motors

FAST, FLEXIBLE CYCLES

Adapt your laundry load to suit your schedule. The Quick 15 Cycle delivers an efficient, 15-minute wash suitable for a small amount of clothes or single items. The Daily 39 program is ideal for your soiled daily loads. And for a regular full load, set to the Full Wash 60 cycle, the ideal one-hour program.

CONVENIENTLY ADD CLOTHES

Have you ever started a wash cycle only to realise that you've left a sock at the bottom of your laundry basket? The AddClothes function allows you to pause the wash to add forgotten items up to 15 minutes after the cycle begins.

Specifications

PRODUCT PROFILE

Domestic warranty details (yrs)	2
Front Loader Type	Front Loader
Capacity (Kg)	9
Frontloader Wash system	UltraMix

ENERGY FOR WASHING

Water Efficiency Star Rating	4.0
WELS Registration Number	C02034
Water Consumption (litres)	82
Energy Efficiency Star Rating	4
Energy Consumption Warm (KWhr/yr)	320
Noise level dBA	52

DIMENSIONS

PRODUCT

Total height (mm)	850
Total width (mm)	600
Total depth (mm)	659

WASH PROGRAMS

Number of Programs	15
Frontloader Wash programs	Delicate, Bedding, Energy Saver, Cotton, Mixed, Quick 15, spin, Tub clean, Rinse & Spin, Baby Care, Daily 39, Full Wash 60, Wool, Sports, Favourite
Wash options	Extra Rinse, Delay End, Prewash, Child Lock, Add Clothes, Hygienic Care, Temperature, Spin Option, Time Manager, wash temperatures
Dispenser	fabric conditioner dispenser, Powder or liquid detergent dispenser, pre-wash dispenser

CONTROLS

Type of controls	electronic interface,electronic rotary
Control panel colour	blue
Functions available	door lock indicator,time remaining,fault diagnostic display,child lock indicator,extra rinse,time manager,cold water,spin speed indicator,delay end,Temperature,UltraMix,Add Clothes,Child Lock
Type of display	LED

DOOR

Door Colour	White
door lock	Yes
Door opening angle	153

WASH PROGRAMS

Wash and Dry Programs	N/A
Wash and Dry options	N/A

BOWL

Drum material	stainless steel
---------------	-----------------

CABINET

Cabinet Colour	white
Cabinet material	painted galvanized steel

DOOR

Door opening mm	341
-----------------	-----

TECHNICAL

Water pressure requirements min	50
---------------------------------	----

Water pressure requirements max	800
---------------------------------	-----

Water supply	cold
--------------	------

Inlet hose length	1500
-------------------	------

Inlet hose extension avail as spare part	Yes
--	-----

Drain hose length	1500
-------------------	------

Drain hose extension avail as spare part	Yes
--	-----

Service cord length	1500
---------------------	------

Motor type	Ecoinverter
------------	-------------

Maximum spin speed	1200
--------------------	------

Variable spin speed	Yes
---------------------	-----

Number of spin speeds	4
-----------------------	---

SHIPPING

Shipping Volume (m3)	.38
----------------------	-----

Shipping Weight (Kg)	73
----------------------	----

Pack Dimensions Height (mm)	870
-----------------------------	-----

Pack Dimension Width (mm)	635
---------------------------	-----

Pack Dimension Depth (mm)	698
---------------------------	-----

STUFFING QUANTITIES

40ft HC	150
---------	-----

Dimensions

Model:
EWF8024Q5WB
EWF9024Q5WB
EWF9042R7WB
EWF1042R7WB
EWF1041R9WB
EWW1042R7WB

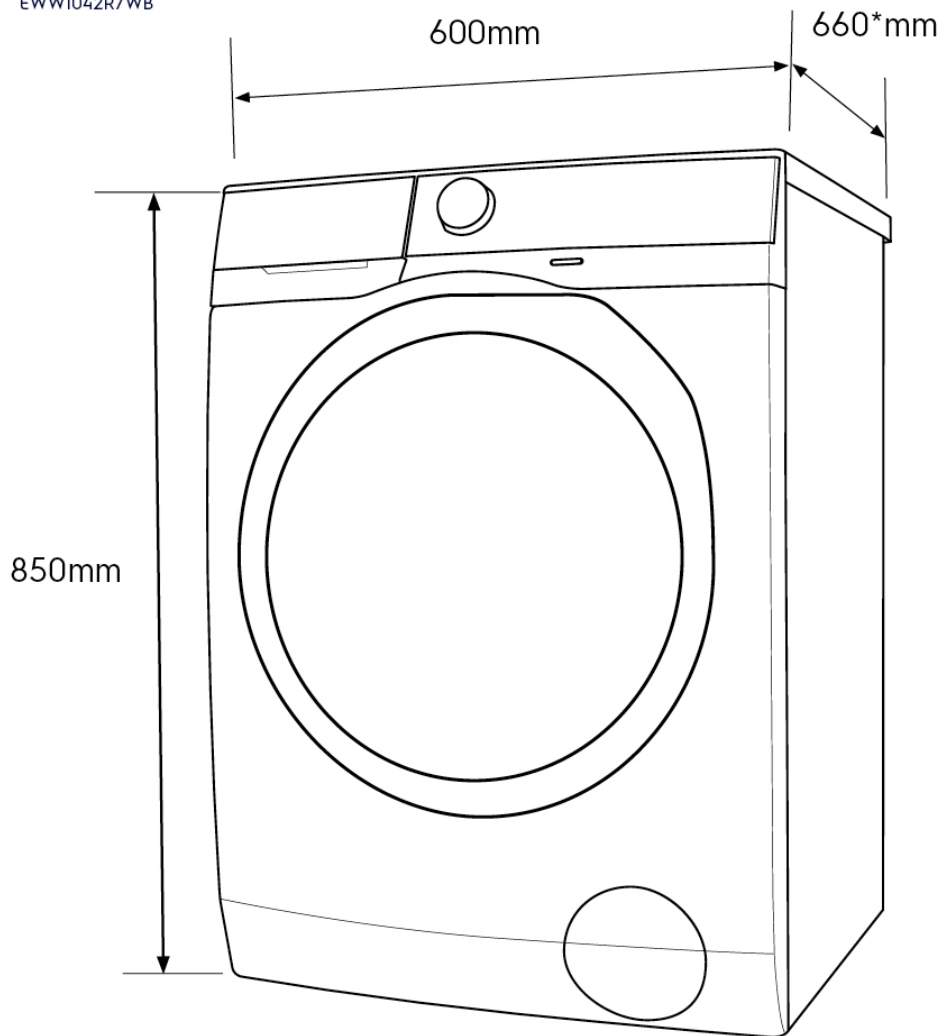

*Add 20mm for the hose protrusion at the back.

IMPORTANT

This is a guide of product dimensions only. For complete installation instructions, refer to the manual provided with product.

Terms and Conditions

IMPORTANT

This is a guide of product dimensions only. For complete installation instructions, refer to the manual provided with product.

PRODUCT INFORMATION

The descriptors and illustrations in this publication apply to the specific products and models described as at the date of issue. Under our policy of continuous product development, product specifications may change without notice. Prospective purchasers should therefore check with their retailer to ensure this publication correctly describes the products that are being offered for sale. All information supplied is to be used for general reference purposes only and is on the understanding that Electrolux Home Products Pty Ltd (Australia) and Electrolux (NZ) Ltd (New Zealand) will not be liable for any loss, liability or damage of whatever kind arising as a result of reliance on such information. Colours of products illustrated are as close as printing limitations allow. Electrolux will at all times comply with its obligations pursuant to law including Trade Practices (Australian Consumer Law) Act and Regulations.

WARRANTY

This warranty only applies to Appliances purchased and used in Australia or New Zealand and used in normal domestic applications and is in addition to (and does not exclude, restrict, or modify in any way) any non-excludable statutory warranties in Australia or New Zealand. All warranties are subject to the conditions set out in the warranty card accompanying the product when purchased.

ELECTROLUX HOME PRODUCTS AUSTRALIA

telephone: 1300 363 640

fax: 1800 350 067

email: customercare@electrolux.com.au

web: www.electrolux.com.au

ELECTROLUX HOME PRODUCTS NEW ZEALAND

telephone: 09 573 2230

fax: 09 573 2221

email: customercare@electrolux.co.nz

web: www.electrolux.co.nz