



Grace Neu 525 Oval vessel Basin

Matte Black | No Tap Hole | No Overflow

Product Image



Product Details

Code:	V1052MB
Brand:	Argent
Range:	Grace
Warranty:	10 Years*
Product Width:	525 mm
Product Depth:	135 mm
WELS:	N/A

Additional Features

Technical Specification

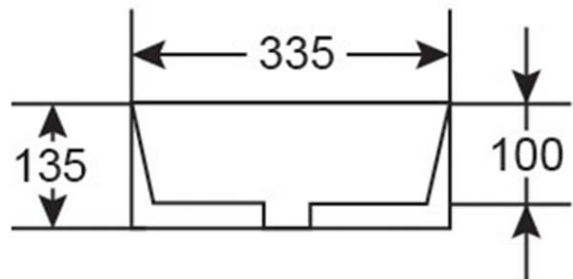
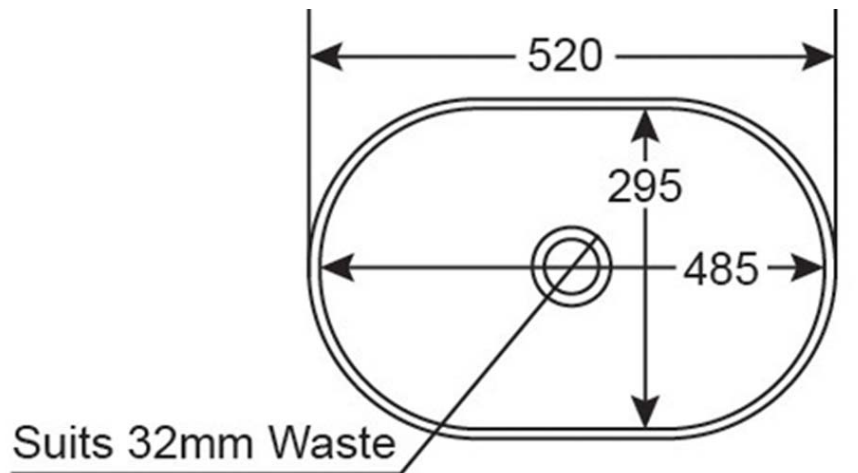

*Please visit argentaust.com.au/warranty to view the full warranty

Note: All dimensions are in millimetres and are subject to normal manufacturing variations. Always use the physical product measurements for cut-outs and rough-ins as the technical details shown may differ from the actual product. Use acetic cured silicone sealant. Do not use epoxy type adhesives. Clean with damp cloth. Do not use abrasive cleaners, liquids or pastes.

