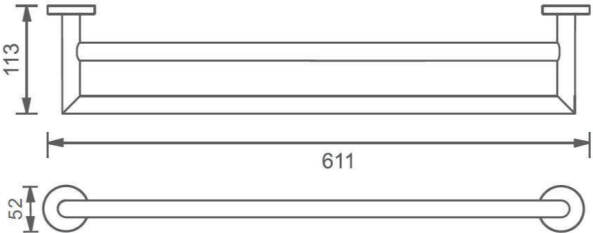

## Hue Towel Rail

Product Image	Technical Specification
	

Description	
<p>Hue Double Towel Rail 600mm Chrome</p>	
<p><b>YS1010</b></p>	<p>Chrome</p>

Attributes
<ul style="list-style-type: none"> <li>• Round wall plates</li> <li>• Flawless chrome finish</li> <li>• Warranty : 7/1years</li> </ul>

\*All dimensions are in millimeters and are subject to normal manufacturing variations. Actual dimensions should be checked prior to installation. Yushi pursues a policy of continuing improvement in design and performance of its products. The right is therefore reserved to vary specifications without notice.