

**90cm multi-function 11 dark stainless steel oven with twin fan system, fast heat up, full touch electronic controls and 125L gross capacity. ONLY AVAILABLE COMMERCIALY.**



## Product Details

### FEATURES

---

Twin Fan System

Fast Heat Up

Full touch electronic control panel

Large 125L gross oven capacity

---

Cooler to Touch Doors

Fingerprint resistant stainless steel

---

### BENEFITS

---

Twin fan system for even cooking

Cook each dish to perfection with the Twin Fan System. Fans rotate in opposite directions, distributing heat evenly throughout the oven, so you enjoy great results every time.

Just a touch for total control

Simple to operate with a sleek design, our full-touch electric control panel with a fully programmable timer ticks all the right boxes. With just a touch or two on the easy clean surface you'll have total control over your cooking temperatures, times and functions.

---

Cooler to touch oven doors

Beautifully designed with Australian families in mind, the multi-layer glazing of our oven doors are cooler to the touch when the oven is hot.

All the room for all your family favourites

If you are serious about creating delicious family feasts and you love entertaining, you'll be right at home with our 90cm oven with a generous 125L gross capacity. That's plenty of room for the biggest Christmas turkey or a weekend roast for all the family. The extra width makes getting things in and out super easy.

---

Built in Australia

Westinghouse, has been the heart of the home for generations and the kitchen appliance brand we have always known and trusted to build reliable products. This oven is built in a local factory in Adelaide.

---

## Specifications

### PRODUCT PROFILE

---

Domestic warranty details (yrs)	2
Type of Oven	single oven
Oven fuel	electric
Materials/Colour	mark resistant stainless steel
Controls of Oven	Full touch electronic control panel
Cooling fan	Yes

### FLUSH FIT CUT OUT

---

Flush fit cut out height (mm)	600
Flush fit cut out width (mm)	900
Flush fit cut out depth (mm)	580

### DIMENSIONS

---

#### PRODUCT DIMENSION

---

Total height (mm)	596
Total width (mm)	895
Total depth (mm)	572

### MAIN OVEN

---

Gross capacity litres	125
Useable capacity litres	116
Oven function	multifunction
Number of functions	11

## MAIN OVEN

Oven Functions	pizza,rapid heat,base heat,fan assist bake,fan grill,defrost,maxi grill,traditional bake,roast,fan forced cooking,grill
Oven liner	pyrolux high temperature enamel
Timer functions	duration,end,minute minder,oven start
Light wattage	25

## ELECTRICAL CONNECTION

Connected load KW	3.6
Maximum current rating (amps)	15
Type of connection	hardwired

## OTHER FEATURES

Cleaning	easy clean door
Door	removable door,removable inner glass panes,drop down
Timer	Fully programmable touch control timer
Lights	2
Light wattage	25
Light position	top
Shelf support	Easy glide side racks
Number of shelves	2

## OTHER FEATURES

---

Safety features	cool door
-----------------	-----------

---

Closed door grilling	Yes
----------------------	-----

---

Fold down grill element	Yes
-------------------------	-----

---

Included accessories	2 x chromed wire shelf,grill/oven pan,grill insert
----------------------	----------------------------------------------------

---

Layers of glass in door	3
-------------------------	---

---

Number of shelf positions	5
---------------------------	---

---

## COOKTOP (IF APPLICABLE)

### PRODUCT PROFILE

---

Knob finish	metalised
-------------	-----------

---

## SHIPPING

---

Shipping Weight (Kg)	70.1
----------------------	------

---

Pack Dimensions Height (mm)	720
-----------------------------	-----

---

Pack Dimension Width (mm)	800
---------------------------	-----

---

Pack Dimension Depth (mm)	1035
---------------------------	------

---

## STUFFING QUANTITIES

---

40ft	96
------	----

---

## Dimensions

### 90cm ovens

WVE915SC, WVEP916SC, WVEP917DSC, WVE915SCA, WVE915DSCA

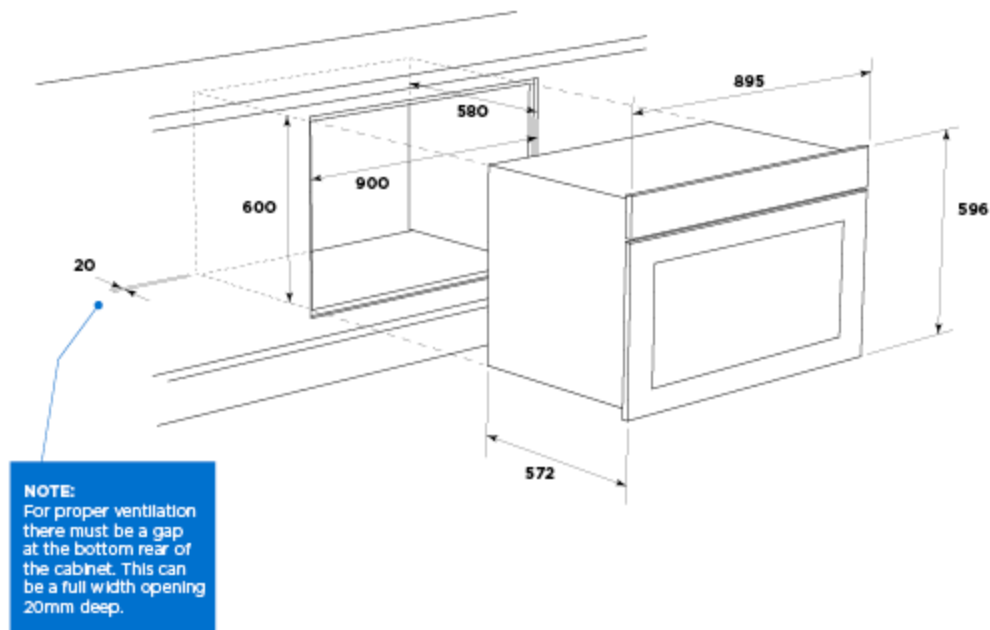

### IMPORTANT

These dimensions are a guide only. All measurements are in millimetres (mm). For complete installation instructions, refer to the manual provided with product.

© 2023 Electrolux Home Products Pty Ltd. ABN 51 004 762 341. W\_DIM\_Aspire\_90cm\_BIO\_Jun23

# Terms and Conditions

## IMPORTANT

This is a guide of product dimensions only. For complete installation instructions, refer to the manual provided with product.

## PRODUCT INFORMATION

The descriptors and illustrations in this publication apply to the specific products and models described as at the date of issue. Under our policy of continuous product development, product specifications may change without notice. Prospective purchasers should therefore check with their retailer to ensure this publication correctly describes the products that are being offered for sale. All information supplied is to be used for general reference purposes only and is on the understanding that Electrolux Home Products Pty Ltd (Australia) and Electrolux (NZ) Ltd (New Zealand) will not be liable for any loss, liability or damage of whatever kind arising as a result of reliance on such information. Colours of products illustrated are as close as printing limitations allow. Electrolux will at all times comply with its obligations pursuant to law including Trade Practices (Australian Consumer Law) Act and Regulations.

## WARRANTY

This warranty only applies to Appliances purchased and used in Australia or New Zealand and used in normal domestic applications and is in addition to (and does not exclude, restrict, or modify in any way) any non-excludable statutory warranties in Australia or New Zealand. All warranties are subject to the conditions set out in the warranty card accompanying the product when purchased.

### ELECTROLUX HOME PRODUCTS AUSTRALIA

telephone: 1300 363 640

fax: 1800 350 067

email: [customercare@electrolux.com.au](mailto:customercare@electrolux.com.au)

web: [www.electrolux.com.au](http://www.electrolux.com.au)

### ELECTROLUX HOME PRODUCTS NEW ZEALAND

telephone: 09 573 2230

fax: 09 573 2221

email: [customercare@electrolux.co.nz](mailto:customercare@electrolux.co.nz)

web: [www.electrolux.co.nz](http://www.electrolux.co.nz)