

60cm freestanding dishwasher, stainless steel, with 15 place settings, AutoDoor, 6 wash programs including Fast 30' and SensorWash, FastDry system, half load option, height adjustable basket when fully loaded, EasyTray cutlery tray and 45dB operation



Product Details

FEATURES

15 place settings A huge 15-place setting capacity	AutoDoor	FastDry FastDry ensures hot steam is removed from the dishwasher, to ensure spotless dishes in no time.	Easytray
Wash programs - 6	SensorWash	Fast wash programs	Height adjustable upper basket
Time Save program	Water safety system	Wash progress indicator	Delay Start - 1 - 24 Hours
Quiet operation	Half load option	Extra fast option	Extra silent option

BENEFITS

Dry dishes every time
Say goodbye to wet dishes and hello to perfectly dry, sparkling results with AutoDoor. At the end of the wash cycle, AutoDoor* springs into action, automatically opening the dishwasher door to allow a powerful burst of air to circulate throughout the interior. This accelerates the drying process, effectively eliminating moisture and leaving your dishes spotless and streak-free. No more towel-drying or waiting for dishes to air dry on the rack, with AutoDoor your dishes are ready to be put away immediately.*Activate AutoDoor when you select the Energy Saver Option on your dishwasher. Energy Saver option can be activated on all programs except PreWash and Steam programs

Fast drying time
Say goodbye to damp dishes with our FastDry system, designed to swiftly whisk away humid air for sparkling dry results every time. Our system dehumidifies hot steam before expelling it from the dishwasher, ensuring minimal humidity remains. With FastDry, enjoy spotless streak free dishes in no time.

Adjusting the right cycle for you

Sensing the level of grime on your dishes, our super smart sensor adjusts the temperature on top of the wash cycle length to ensure the best results. As well as saving water.

Superior cleaning every wash

Wash all your dirty dishes together with DualWash. With lower water pressure and temperature in the top basket, perfect for glassware and higher pressure and temperature in the lower for pots and pans, you can wash all in one without compromise. Plus, the inverter technology will keep noise to a minimum, so you can continue doing what you love.

Removable cutlery tray

Our Easy Tray is designed for convenience. With its effortless removal feature, transferring cutlery in and out of your dishwasher has never been easier. Simply pick one or both trays, place on your benchtop and put your cutlery away, without the back and forth shuffle of going back to the dishwasher. If you need extra space in your wash, remove the cutlery tray completely and you can fit larger items on to top shelf.

Make room for larger items

Those extra large items can now fit with ease in the bottom basket with our height adjustable upper basket. Even if its fully loaded, it's easily lifted to fit the most awkward item underneath.

Specifications

PRODUCT PROFILE

Domestic warranty details (yrs)	2
---------------------------------	---

Type of Dishwashers	freestanding
---------------------	--------------

Design family (eline)	Family Size Dishwasher
-----------------------	------------------------

Place settings	15
----------------	----

Drying system	turbo dry
---------------	-----------

Number of spray arms	2
----------------------	---

Top shower	Yes
------------	-----

DIMENSIONS

Total height (mm)	850
-------------------	-----

Total width (mm)	598
------------------	-----

SPECIFICATION

Water Efficiency Star Rating	5
------------------------------	---

WELS Registration Number	D02962
--------------------------	--------

Water consumption (litres)	12.2
----------------------------	------

Energy Efficiency Star Rating	4
-------------------------------	---

Energy consumption cold water (kWhr/yr)	245
---	-----

Noise level dBA	45
-----------------	----

Water supply	cold or hot (maximum 60°C)
--------------	----------------------------

Basket colour	grey
---------------	------

Service cord length	180
---------------------	-----

WASH PROGRAMS

Number of Programs	6
--------------------	---

DIMENSIONS

Total depth (mm)	598
Height adjustment (mm)	20

CONTROL PANEL

Control panel type	Push button electronic,LED Display
Top mounted control panel	No
Control panel finish	black
Knob or button finish	black
Display indicators	time remaining, wash program, wash progress, rinse aid, lock, delay start, ExtraSilent, EnergySaver, on/off, half load, program selected, tablet function, ExtraHygiene

EXTERIOR

Door finish	dark stainless steel
-------------	----------------------

WASH PROGRAMS

Programs	fast 30min, Eco 50°C, Time Save 50 minutes, Delicate, SensorWash Heavy (60 - 70°C), Dual Wash 60°C
Wash option	EnergySaver, Delay start (1-24 hours), Tablet, Extra silent, Extra fast, Extra hygiene, Power half load (3 mode)

FEATURES

Other Features	child lock on control panel, Soil Level Sensor, AutoDoor, delay start
Water safety system	overflow protection, bottom catchment tray, anti-flood protection, aqua control
Filter system	3 stage
Dispenser	detergent, rinse aid

UPPER BASKET

Upper basket features	height adjustable on full load
-----------------------	--------------------------------

EXTERIOR

Side colour	black
-------------	-------

Plinth colour (kickboard)	Dark stainless steel
---------------------------	----------------------

LOWER BASKET

Foldable Racks	4
----------------	---

HOSES

Inlet hose length	170
-------------------	-----

Drain hose length	180
-------------------	-----

Inlet hose length (metres)	1.47
----------------------------	------

Drain hose length (metres)	1.80
----------------------------	------

extension hose	spare part
----------------	------------

STUFFING QUANTITIES

20ft	48
------	----

40ft	102
------	-----

UPPER BASKET

Foldable cup shelves	4
----------------------	---

Foldable Racks	2
----------------	---

THIRD TRAY

Tray features	Cutlery Tray,Removable
---------------	------------------------

SHIPPING

Shipping Weight (Kg)	50
----------------------	----

Pack Dimensions Height (mm)	881
-----------------------------	-----

Pack Dimension Width (mm)	644
---------------------------	-----

Pack Dimension Depth (mm)	661
---------------------------	-----

STUFFING QUANTITIES

40ft HC	153
---------	-----

Dimensions

Freestanding Dishwasher

WSF6602WB / WSF6602XB
WSF6604WB / WSF6604XB
WSF6606XB / WSF6606KXB
WSF6608XB / WSF6608KXB

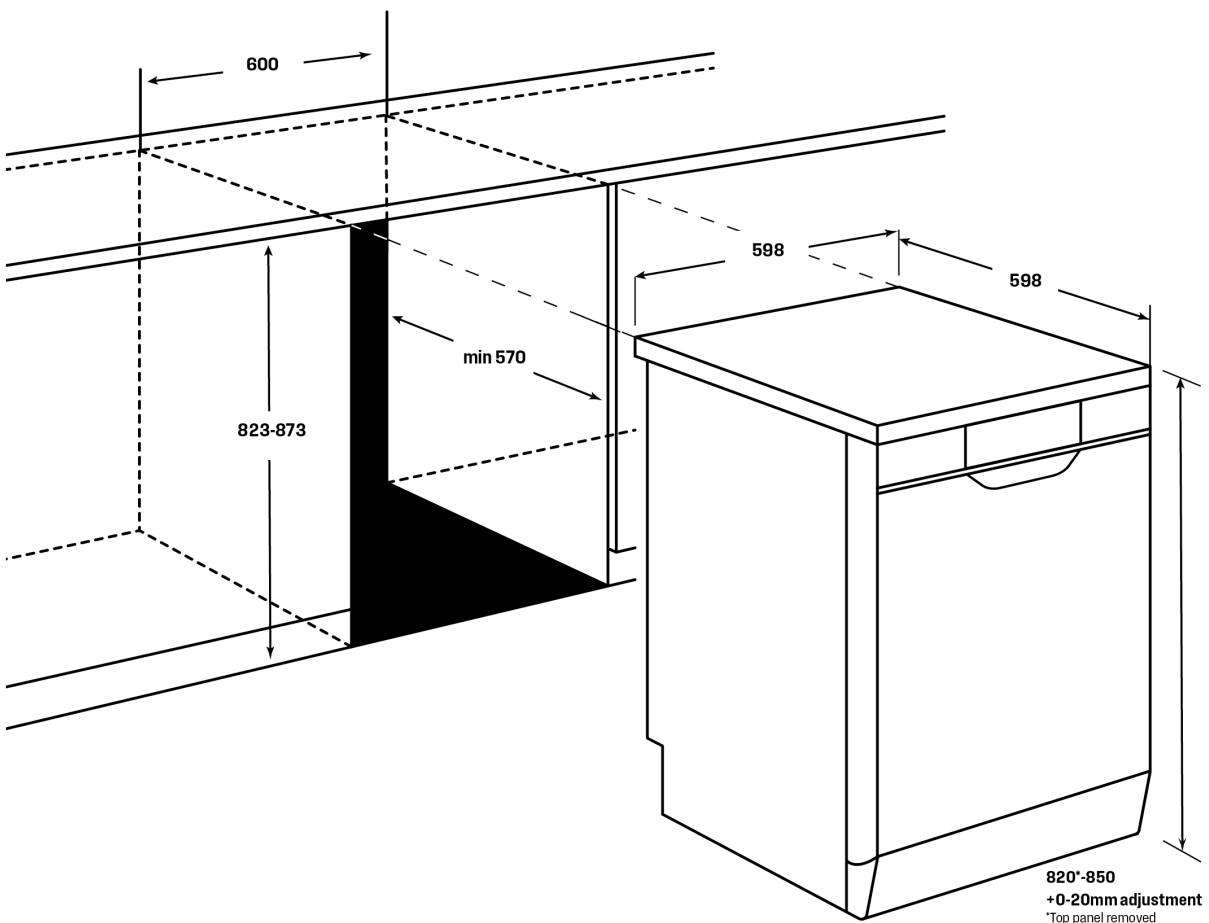

IMPORTANT

These dimensions are a guide only. All measurements are in millimetres (mm).
For complete installation instructions, refer to the manual provided with product.

Terms and Conditions

IMPORTANT

This is a guide of product dimensions only. For complete installation instructions, refer to the manual provided with product.

PRODUCT INFORMATION

The descriptors and illustrations in this publication apply to the specific products and models described as at the date of issue. Under our policy of continuous product development, product specifications may change without notice. Prospective purchasers should therefore check with their retailer to ensure this publication correctly describes the products that are being offered for sale. All information supplied is to be used for general reference purposes only and is on the understanding that Electrolux Home Products Pty Ltd (Australia) and Electrolux (NZ) Ltd (New Zealand) will not be liable for any loss, liability or damage of whatever kind arising as a result of reliance on such information. Colours of products illustrated are as close as printing limitations allow. Electrolux will at all times comply with its obligations pursuant to law including Trade Practices (Australian Consumer Law) Act and Regulations.

WARRANTY

This warranty only applies to Appliances purchased and used in Australia or New Zealand and used in normal domestic applications and is in addition to (and does not exclude, restrict, or modify in any way) any non-excludable statutory warranties in Australia or New Zealand. All warranties are subject to the conditions set out in the warranty card accompanying the product when purchased.

ELECTROLUX HOME PRODUCTS AUSTRALIA

telephone: 1300 363 640

fax: 1800 350 067

email: customercare@electrolux.com.au

web: www.electrolux.com.au

ELECTROLUX HOME PRODUCTS NEW ZEALAND

telephone: 09 573 2230

fax: 09 573 2221

email: customercare@electrolux.co.nz

web: www.electrolux.co.nz