

stylus

Symphony

PAN FIXING PROCEDURE

Roughing Procedure

The soil pipe and pan collar should be accurately fixed into position as recommended for Caroma cisterns, as detailed in **Figure 1** and **Figure 2**.

'S' trap installation

* For VC cisterns with Trident & Caravelle seats
165 is the minimum setout

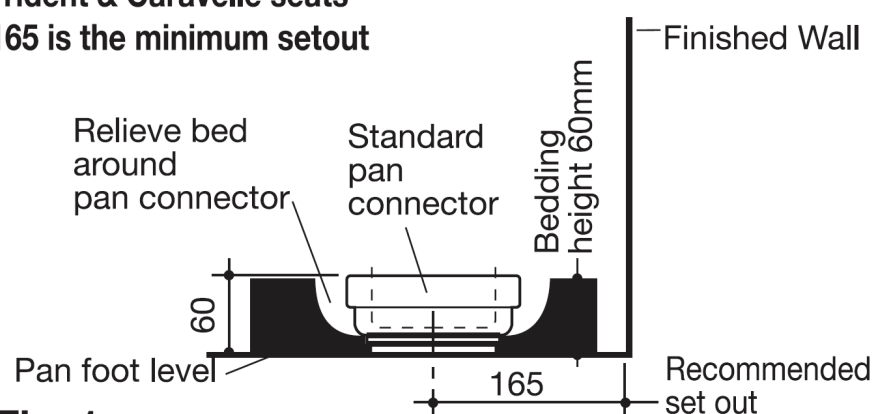

Fig. 1

IMPORTANT: ALL DIMENSIONS ARE TO THE UNDERSIDE FOOT LEVEL OF THE PAN. IT IS IMPORTANT TO MAKE A HEIGHT ALLOWANCE FOR BEDDING.

'P' trap installation

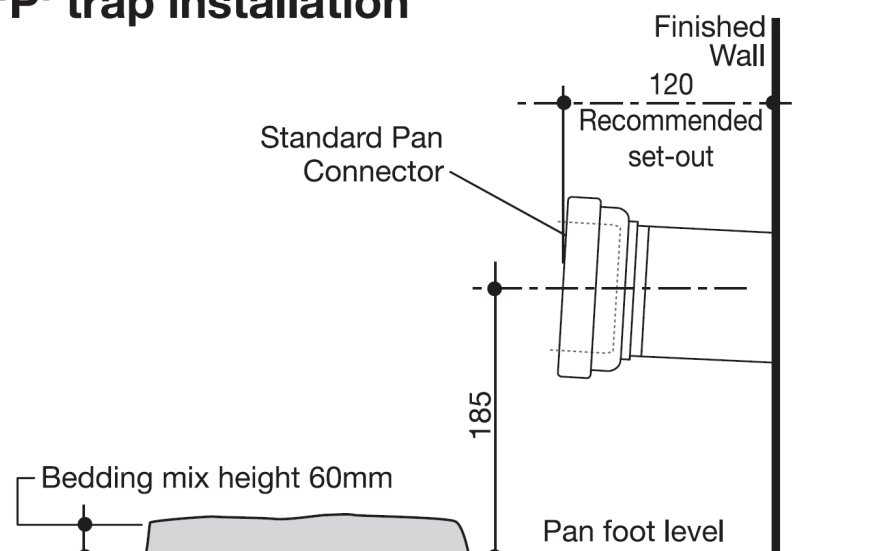

Fig. 2

Pan Bedding :

- 1- Remove an area of tiles which are within the internal area covered by the foot of the pan to expose the subfloor to provide a bondage key for the bedding mixture.
- 2- Ensure that bedding area is clean and free of building material.
- 3- Prepare bedding sand cement mixture 3:1 to depth of 60mm as detailed in **Figure 1** or **Figure 2**.

NOTE : Do not fill the foot of the pan with bedding mix or include lime or fast drying cement in the mix, these may cause cracking in the foot of the pan.

- 4- Position pan and connect with pan connector then level pan into bedding mixture, so that the back of the foot of the pan is approximately 10mm above the finished floor as detailed in **Figure 3**. It is recommended that wedges are used to support the foot of the pan during the positioning.

SCREW FIXING :

- 1- Position pan onto pan connector . Adjust pan position if necessary and mark location of pan fixing holes on the floor. Remove the pan.
- 2- Drill two holes in the marked positions on the floor. The hole diameter is dependent on the type of fixing system and floor finish.

IMPORTANT- DO NOT USE THE PAN SCREW HOLES AS A GUIDE FOR DRILLING AS THIS MAY CRACK THE PAN.

- 3- Ensure that the area around the floor is clean and free from building material.
- 4- Run a bead of acetic cured silicone sealant at a height of 8mm approximately fully around the foot of the pan which contacts the floor. Use Wedges around the foot base (if required) so that the maximum height of silicone sealant is not greater than 5mm on completion on bedding.
- 5- Connect pan to pan connector and fix to the floor with suitable corrosion resistant screws. Level the pan with the acetic cured silicone sealant to the finished floor. Remove any excess sealant.

Figure 3

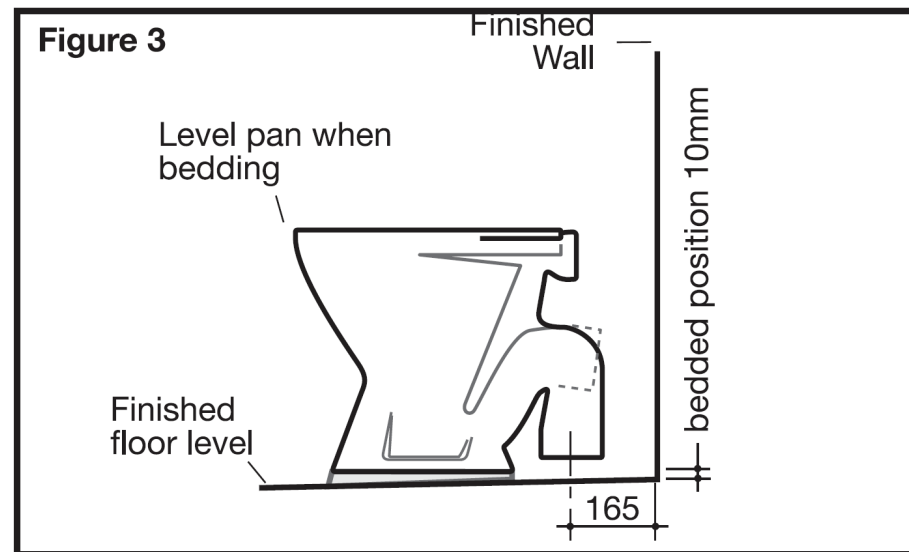

VITREOUS CHINA

FRAGILE

HANDLE WITH CARE

**AVERAGE WEIGHT
13 KILOGRAMS**

tributed by Stylus Pty Ltd
ABN 27 009 685 947

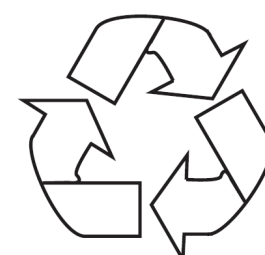

RECYCLABLE PACKAGING



Australian Standard



WaterMark
AS 1172
Lic SMK1368/1
WMKA1368/1
SAI Global