

Model RBA1882-100-502 incl. Small Mounting Plate

Materials & Features

Wave-n-Go™ activated mains pressure dual flush valve for WELS 6/3L and 4.5/3L WC applications. Supplied complete with integrated isolating ball valve and strainer, electronic flush valve, Wave-n-Go™ sensors and vacuum breaker. Watermark certified for direct connection to the drinking water supply. A range of standard and custom stainless steel face plates are available to suit commercial installations.

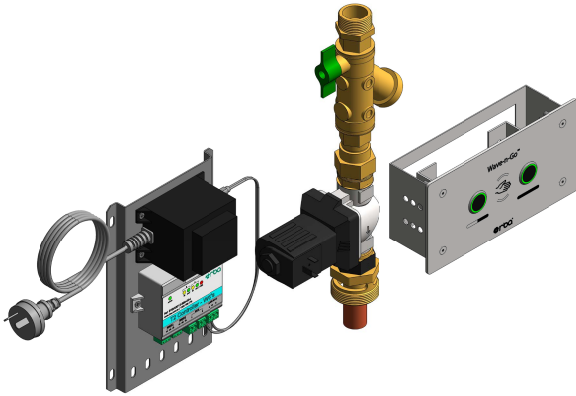

Electrical Detail

Temperature Range: 5°C - 55°C
 Solenoid Cable: 2M x 32/0.20ELCF2810 1.00mm²
 Transformer: 240VAC/24VAC, 3 AMP

Hydraulic Detail

Inlet Connection: DN 25mm min.
 Outlet Connection: DN 40 to suit DWV
 Water Supply Pressure: 300kPa min – 500kPa max.
 Flush Pipe: DN40 (Supplied by others)
 Flush Volume: WELS 3 Star 6/3L or 4 Star 4.5/3L
 Flow Rate: Nominal 1.4 LPS

Available Models

RBA1882-100-502 Wave-n-Go™ Touch-Free Dual Flush Valve Small Plate

Related Products

- RBA1882-100** Flush Valve Bare
- RBA1882-100-501** Wave-n-Go™ Touch-Free Dual Flush Valve incl. Large Mounting Plate
- RBA1882-100-503** Wave-n-Go™ Touch-Free Dual Flush Valve incl. Small White Mounting Plate
- RBA1882-100-505** Wave-n-Go™ Dual Flush Valve incl. Small Black Mounting Plate
- RBA1882-100-507** Wave-n-Go™ Touch-Free Dual Flush Valve incl. Large Mounting Plate to suit AS1428.1

Installation

All water services supplying the valve shall be hydraulically calculated in accordance with the Plumbing Code of Australia and AS/NZS3500. RBA recommends that only 1 x 90° bend be used however 2 x 45° bends may also be used if required. For optimum performance, it is also recommended that a distance of 700mm +/- 100mm be maintained between the outlet of the vacuum breaker and the centre line of the flush pipe connected to the WC pan inlet (min. distance is 450mm as per AS/NZS3500). Each flush valve is supplied with a 24V AC transformer for connection to 240V mains supply.

Valve is intended for vertical installation only.

Important: Installation instructions and current rough-in details should be furnished with each fixture. Do not rough in without certified dimensions. Dimensions are subject to manufacturer's tolerance of +/-10mm.

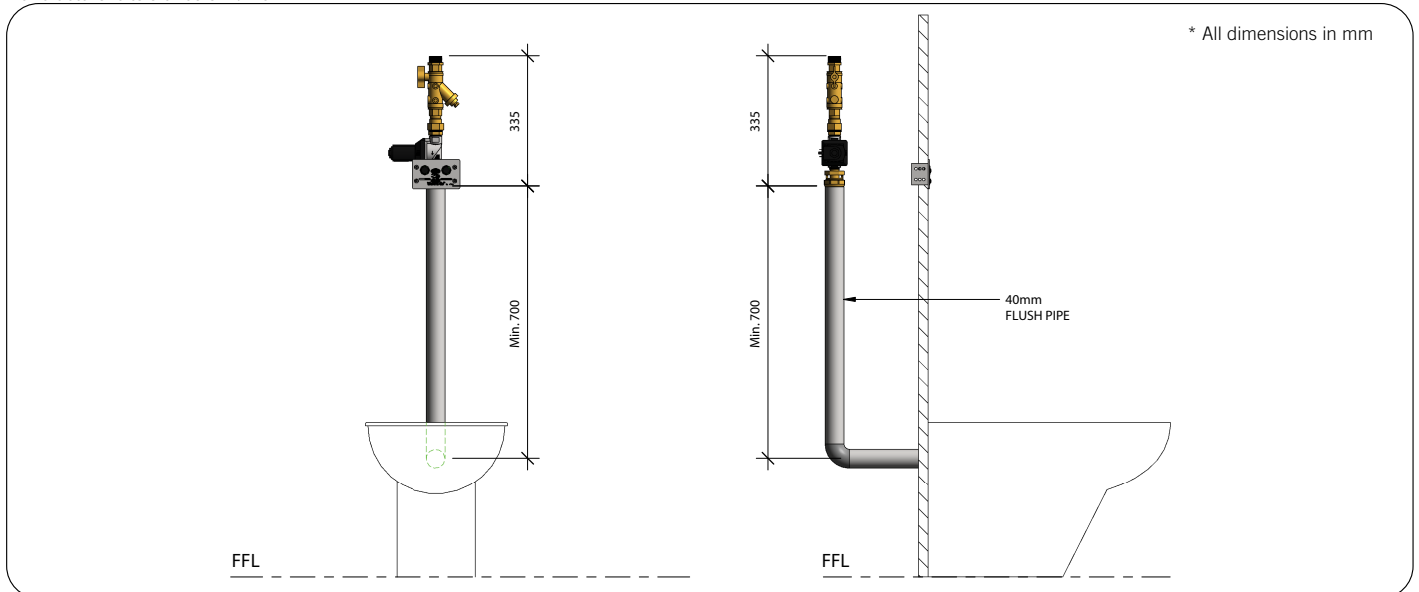

Wave-n-Go™
 Touch-Free Sensor



As improvements in the design and performance of RBA products are continuous, specifications may be subject to change without notice. The illustrations and descriptions herein are applicable to production as of the date of this Technical Data Sheet. Revised 09/24 © 2024 by RBA Group TD/Model RBA1882-100-502/0924