

Model RBA1110-650



Materials & Features

Commercial shower mixer is designed for public washrooms, aquatic centres, schools, change rooms, stadiums & surf clubs. Valve is activated by lifting the lever and turning left or right to achieve the desired temperature. Mixer is suitable for Accessible installations.

Technical Detail

Valve Body:	DZR brass
Handle:	Chrome plated brass
Escutcheon:	Chrome plated brass
Inlet Connection:	15mm BSP (1/2")
Outlet Connection:	15mm BSP (1/2")
Operating Pressure:	Min: 100kPa Max: 500kPa

Available Models

RBA1110-650 oken Shower Mixer w/- Round Plate

Related Products

- RBA4110-936** RH Shower T-Rail, incl Handset, Hose & Slider
- RBA4110-937** LH Shower T-Rail, incl Handset, Hose & Slider
- RBA8519-107** Commercial Showerhead, 7.0Lpm

Note: For Australia, Installation shall be in accordance with the PCA [Plumbing Code of Australia] and any relevant local authority requirements. When installing to meet AS1428.1, ensure no less than 50mm clearance is left between handle and escutcheon as per Section 12.2.1 (b)

Important: Installation instructions and current rough-in details should be furnished with each fixture. Do not rough in without certified dimensions. Dimensions are subject to manufacturer's tolerance of +/-10mm.

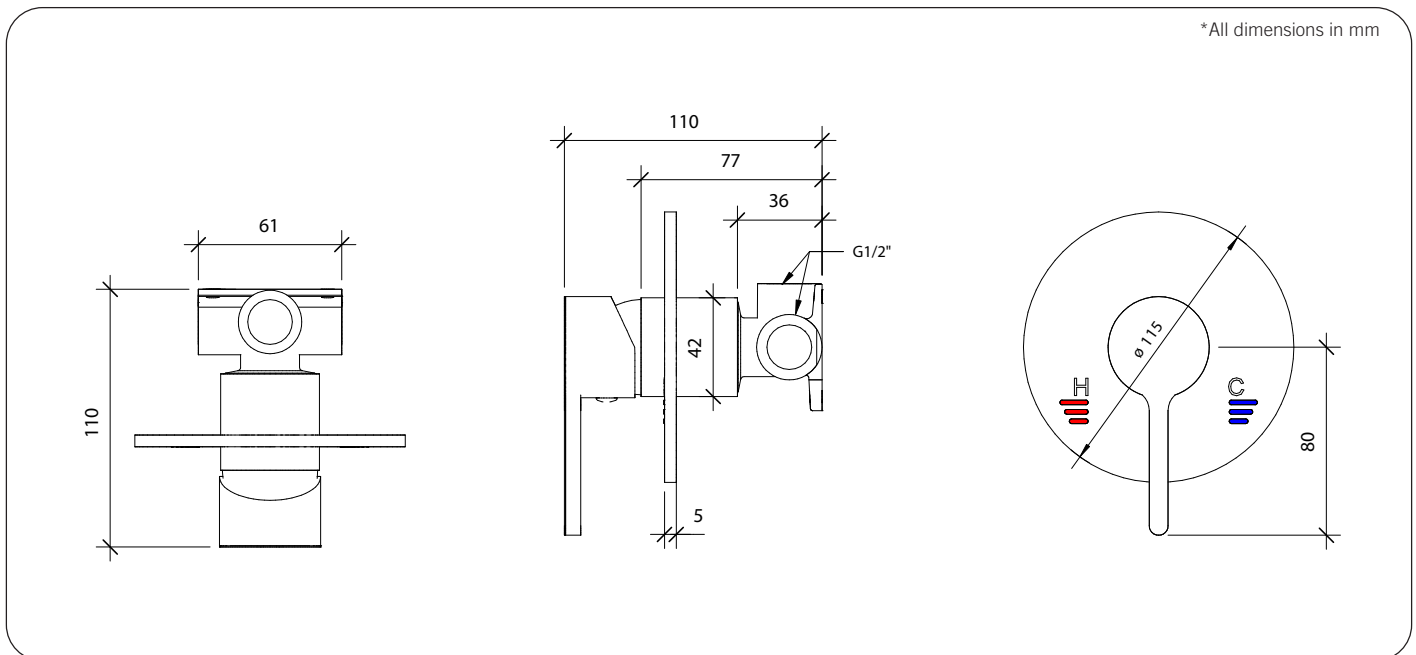

As improvements in the design and performance of RBA products are continuous, specifications may be subject to change without notice. The illustrations and descriptions herein are applicable to production as of the date of this Technical Data Sheet. Revised 10/22 © 2022 by RBA Group TD/Model RBA1110-650/1022