

**Model: 10332 IXL Eco Ventflo Ceiling Exhaust Fan with Draught Shutters 200,**  
**Model: 10333 IXL Eco Ventflo Ceiling Exhaust Fan with Draught Shutters 250,**  
 (Electric Rating: 230-240 V. 50Hz)

**Safety** **Do not allow insulation material to rest against the sides or top of the Ventilation unit when installed**

Read through these instructions fully before commencing installation.

Locate the IXL Ventflo in accordance with the requirements of the current Australian/New Zealand Wiring Rules AS/NZS 3000 relating to damp situations, or according to applicable Wiring Rules for installations outside of Australia and New Zealand.

In some installations this may mean that no part of the appliance may be located directly above any part of a bath or shower recess or enclosure. For unenclosed showers refer to Wiring Rules conditions. This unit is fitted with a cord and plug, however, any interconnecting wiring and switches used or use of another cord and plug must be fitted by a licensed electrician.

Switches and other controls must not be located where they can be touched by a person in the bath or shower.

**Warning:**

- Pull out the power plug before cleaning or maintenance.
- Do not use this appliance for functions other than those described in this user guide.
- After removing the appliance from its packaging, ensure that it is complete and undamaged.
- If in doubt contact a qualified electrician or IXL Home. Do not leave packaging within the reach of children or infirm persons.
- This appliance is not intended for use by persons (including children) with reduced physical, sensory or mental capabilities, or lack of experience and knowledge, unless they have been given supervision or instruction concerning the use of the appliance by a person responsible for their safety.
- Young children should be supervised to ensure they do not play with the appliance.
- Do not operate the appliance in the presence of inflammable vapours (alcohol, insecticides, petrol, etc.)
- Do not sit or place objects on or in the appliance.
- The supply cord cannot be replaced. If the cord is damaged the appliance should be scrapped.
- Do not operate this appliance without the plastic surround in position.
- This appliance must be mounted with the lowest point at least 2.1 metres from the floor.
- Ensure that the fan is switched off from supply mains before removing the grille/guard.

**Caution:**

- Do not make modifications of any kind to this appliance.
- Do not expose this appliance to the weather (rain, sun, etc.)
- Do not immerse the appliance or any parts of it in water or other liquids. Refer to the relevant instructions to clean the appliance (refer to **Cleaning**).
- If the appliance does not function correctly or develops a fault, contact IXL Home immediately.
- Should the appliance be dropped or suffer a heavy blow, have it checked by an authorised service agent for IXL products.
- The electrical system to which the appliance is connected must conform to applicable standards.
- The electrical power supply/socket to which the appliance is to be connected must be able to provide the maximum electrical power required by the appliance. If it can't do this, contact a qualified electrician to make the necessary modifications.
- Switch off the appliance at the installation's main switch: a) if the appliance does not function correctly; b) before cleaning the outside of the appliance; c) if the appliance is not going to be used for any length of time.
- The room must have an adequate source of replacement air for this appliance to function effectively. Moreover, if there is any non-sealed combustion based appliance such as a water/gas heater, gas stove etc. in the same room, air replacement must be sufficient for all appliances to work effectively together.
- Keep the appliance's inlet grille/guard free from dust to ensure optimum air flow.

## Clearances

All appliances must be mounted so that the lowest point is at least 2.1m above the floor.

The IXL Eco Ventflo is designed to fit a ceiling cavity with a minimum height of 155mm (10332) & 200mm (10333) when installed in a well ventilated roof cavity. Where ventilation is restricted, these heights should be increased by a minimum of 60mm. This will allow for the back draught shutters to open fully when the unit is in operation.

Additionally, a minimum of 40mm clearance is required between the sides of the fan and any adjoining parts of the roof structure, such as walls, joists or insulation batts.

**Figure 1 measurement A:**

Model 10332 (Eco Ventflo 200) 155mm min. where there is good ventilation to the sides of the unit. 215mm min. where ventilation to the sides of the unit is restricted.

Model 10333 (Eco Ventflo 250) 200mm min. where there is good ventilation to the sides of the unit. 260mm min. where ventilation to the sides of the unit is restricted.

**Figure 1 measurement B:**

40mm min. clearance on all sides to allow clips to fully rotate outwards.

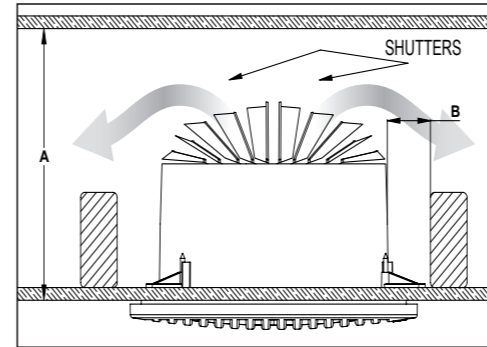

Fig. 1: Minimum clearances for installation.

## Flat Roof Installations

When installing into a flat roof with insufficient clearance, or where ceiling cavity ventilation is restricted, an external venting duct must be installed. Use Fig. 2 as a guide to minimum external outlet requirements.

**IMPORTANT:** Do not attach the duct to the body of the fan. Allow for 10-20mm minimum gap between the fan and the end of the duct.

The duct should have a diameter of at least 235mm (10332) & 290mm (10333).

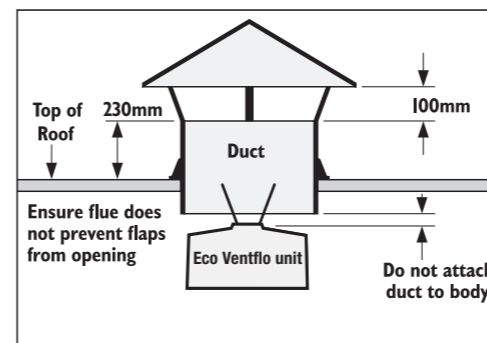

Fig. 2: Minimum external outlet requirements.

## Electrical Requirements

See the wiring diagram (Fig. 3) for supply requirements and maximum loadings for each model. Fans may be connected to a lighting power circuit if loading permits. Wiring of the wall switch (not provided) and socket outlet in roof cavity must be carried out by a registered electrician. The wall switch should be located in accordance the Wiring Rules AS/NZS 3000. It must not be installed where it can be reached by a person in the bath or shower.

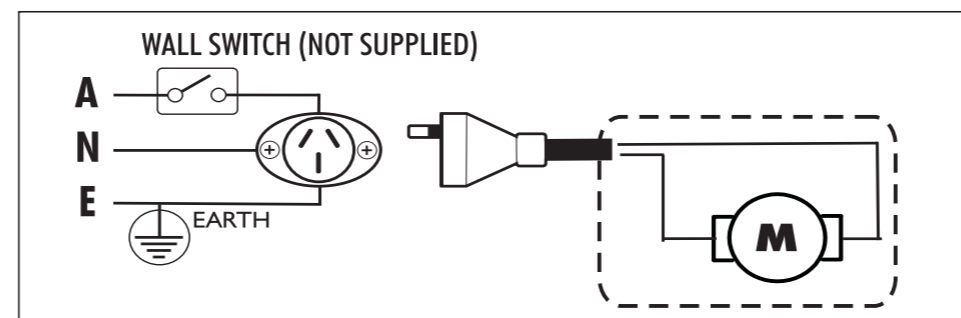

Fig. 3: Wiring diagram.

## Ventilation Requirements

For maximum efficiency and fan performance there are a few key points to keep in mind when installing your IXL Eco Ventflo exhaust fan.

**Sufficient air inlet into room**

Steam will only be removed if there is sufficient flow of air through the room. Ensure generous inlets exist through windows, vents or under the door. Air flow path from inlet to fan should ideally pass over the steam sources. (See Fig 4.)

**Adequate ventilation in roof cavity**

It is essential that there is adequate space within the roof cavity so that exhaust air from the fan can dissipate. Where space is restricted, use Fig. 1 as a guide to minimum requirements for adequate ventilation.

The roof cavity itself should be well ventilated to outside so that moist air can be removed. Local building codes may require flueing to outside through roof as per Fig. 2 for flat roof installation.

**Where ventilation space is restricted**

This product is not recommended for installation between floors of multi-storey dwellings, or where space within the roof cavity is severely restricted and a flue as per Fig. 2 cannot be fitted. IXL has other Ventilation products available that are particularly suited to installations between floors or where space is restricted.

For further details and advice on ventilation products and tips, contact our retail partners or IXL Home customer service team.

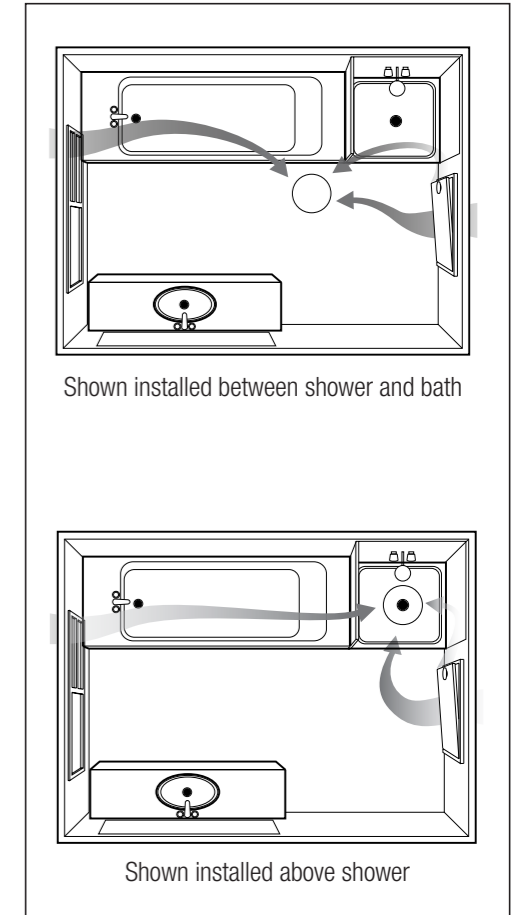

Fig. 4: Ideal placement of Eco Ventflo. Sufficient air inlets into room are required.

**Model: 10332 IXL Eco Ventflo Ceiling Exhaust Fan with Draught Shutters 200,**  
**Model: 10333 IXL Eco Ventflo Ceiling Exhaust Fan with Draught Shutters 250,**  
 (Electric Rating: 230-240 V. 50Hz)

### Installation

#### Important considerations before installing

- Remove protective packaging from the product before installation.
  - Joists, beams and rafters shall not be cut or notched to install the appliance.
  - For the exhaust fan to work efficiently, replacement air of a volume equivalent to what is being extracted must be able to enter the room. In general this air would be drawn under the door or through a slightly open window. If the room is airtight the fan will function poorly.
  - This product is designed for installation in flat ceiling only. Do not mount it on a sloping ceiling or vertical wall.
1. Locating the unit – Before commencing any cutting, check in the ceiling space that there are no obstructions such as ceiling joists and that there is sufficient clearance for the housing. Check that the electrical wiring can be routed from the wall switches to the mounting location.
  2. Prepare the ceiling – Using the template provided, mark the ceiling with a pencil outline and cut out the required hole (10332 needs 240mm dia. & 10333 needs 295mm dia. hole).
  3. Remove the grille (simply turn anti-clockwise to unlock), see (Fig.5)
  4. Plug the fan into the power point.
    - a. Before inserting the fan into the opening, push the three bar clamps all the way out to hold the fan in the ceiling. Push the fan into the ceiling opening and secure the exhaust fan by tightening the screws securely (Fig.6)
    - b. For thicker ceilings (13mm or more), remove the three bar clamps. Use wood screws (not supplied) to secure the fan to the ceiling. Locate screws in the 3 holes in the outer lip of the fan frame.
  5. Using a screwdriver (or a battery driver with a low torque setting) partially tighten the screws. This will move the mounting clips into the open position and hold the unit to the ceiling.
  6. Rotate the unit so that the grille direction lines on the body are aligned with the walls. These lines show the orientation of the fascia grille when installed.
  7. Do not over tighten the screws as this can damage plasterboard.
  8. Fit grille onto unit. Once fitted the grille can be adjusted to better align with the walls.

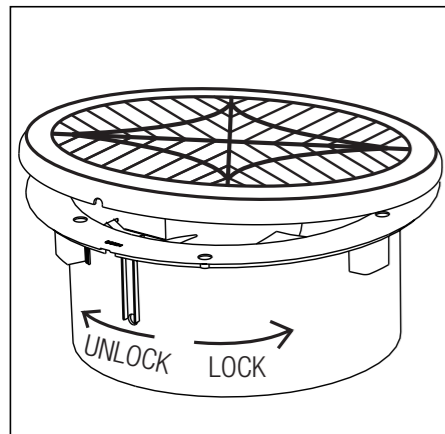

Fig. 5

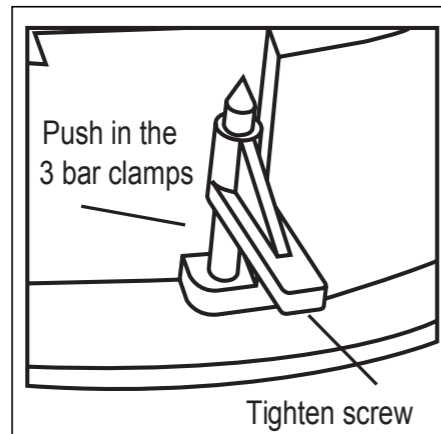

Fig. 6

### Use

1. Turn the power switch on/off to make sure the unit runs.
2. Running the fan can exhaust steam and odours quickly and efficiently.  
 Note: Shut off power urgently when any abnormalities occur in operation. Then call a licensed electrician or IXL service person for inspection and necessary service work.  
 Do not insert fingers or thin bars into the grille when the unit is operating. This could cause harm to yourself and the appliance.  
 The unit must not be installed in a place that suffers from severe water leakage.
3. When the unit is switched off, the draught shutters when closing, will make a slight sound. This is normal operation.

### Cleaning

1. Shut power off before cleaning or maintenance.
2. Remove grille and wipe it with care using a damp soft cloth with a mild detergent if necessary. Ensure the motor or other electrical parts can't touch the water.
3. The grille can be cleaned in a dishwasher on low heat setting ~45°C and only wash on the top shelf.
4. Replace the grille from the dishwasher after it is thoroughly dry.

### Warranty

#### Two Year Replacement Warranty

This Warranty against defects for your newly purchased IXL product is proudly prepared by IXL Home Pty Ltd of 1K Marine Parade, Abbotsford, VIC 3067, phone 1300 727 421.

1. IXL Home Ventilation products come with guarantees that do not exclude the following consumer entitlements under the Australian Consumer Law:
  - a. replacement or refund for a major failure and compensation for any other reasonably foreseeable loss or damage; and
  - b. to have the goods replaced if goods fail to be of acceptable quality and the failure does not amount to a major failure.
2. IXL Home warrants that your product and related supply will be free from defects in materials and workmanship during the warranty term.  
 Your warranty term is two years commencing from the date of purchase.
3. Subject to Point 1, IXL Home will during the warranty term provide a replacement of an equivalent current model where the balance of the warranty period from the original date of purchase will take effect.
4. To the fullest extent permitted by law and subject always to Point 1, IXL Home will not be liable for:
  - a. any loss or damage arising from loss of use, loss of profits or revenue; or
  - b. for any indirect or consequential loss or damage resulting from any breach of this warranty against defects.
5. Defective IXL Home products may be replaced by a refurbished product of the same type.

#### Limitations to Your IXL Warranty

6. Subject to Point 1, this Warranty:
  - a. will only be provided to the original purchaser where the original purchase was made from a IXL Home Authorised Dealer or Reseller and proof of such purchase can be presented at the time of service;
  - b. only applies to IXL Home products purchased in Australia and New Zealand from an IXL Home Authorised Dealer or Reseller;

- c. will not apply where the defect in or failure of the product is attributable to misuse, abuse, accident or non-observation of the manufacturer's instructions. This product must be used in accordance with the manufacturer's instructions;
- d. will not cover faults due to normal wear and tear with reasonable use nor consumable components such as globes, filters, glass items etc;
- e. will not cover any damages or problems caused to this product by natural forces eg. storm, fire, flood, and earthquake; or by intrusion or accumulation (or both) of foreign matters eg. dust, soil, and moisture. IXL Home recommends that you take out appropriate insurances to protect your product to this end;
- f. will not apply if this product is installed in a mobile dwelling eg. caravan or boat;
- g. will not apply if this product is removed from the location where it was first installed;
- h. covers use of this product for domestic use only;
- i. will not be restarted or extended upon replacement of the product or a part.

#### How to Make a Claim Under Your IXL Warranty

7. To make a claim under this Warranty you will need to:
  - a. contact IXL Home customer service department on 1300 727 421 or [service@ixl.com.au](mailto:service@ixl.com.au) to provide details and register your claim enabling a IXL Home assessment;
  - b. submit proof of purchase with your claim eg. tax invoice or purchase receipt;
  - c. where a property has been constructed by a builder/developer and it is fitted with IXL products, please submit proof of purchase by way of the certificate of occupancy, with your claim.
8. IXL Home will contact you to make arrangements for a replacement product.

### Privacy

The privacy of your personal information has always been important to us. To learn more about how we collect, keep and use your personal information, please obtain a copy of our privacy statement by visiting our website at:

[www.ixlappliances.com.au](http://www.ixlappliances.com.au) or by contacting us via email on [orders@ixl.com.au](mailto:orders@ixl.com.au) or by telephone on 1300 727 421.

### IXL Home

1K Marine Parade, Abbotsford, Victoria 3067 Australia. Free Call: 1300 727 421

[www.ixlappliances.com.au](http://www.ixlappliances.com.au) | [orders@ixl.com.au](mailto:orders@ixl.com.au)

New Zealand - Free Call: 0800 727 421 | [www.ixlappliances.co.nz](http://www.ixlappliances.co.nz) | [orders@ixl.com.au](mailto:orders@ixl.com.au)

IXL and Ventflo are registered trademarks of Alver Pty Ltd in Australia and New Zealand used under licence by IXL Home Pty Ltd.

Made in China