

Commercial Exclusive: This black freestanding dishwasher features simple to use electronic controls, and 5 wash programs, including Rapid 30 min wash and an energy saving ECO wash. Enjoy the added benefits of a half load feature and a quiet 52dB(A) noise level.



Product Details

FEATURES

14 place setting

Push-button electronic controls

Rapid 30 wash program

Half load option

Child Lock Mode

The child lock feature can be selected to reduce the possibility of children starting the dishwasher when unattended.

Delay start

The wash programme may be started after a designated amount of time

BENEFITS

Simple to use controls

This dishwasher features a simple push button control with a button for each program.

Saves water

With today's climate challenges, we need to do what we can to save water. That's why we offer 4.5 star WELS water rated dishwashers, so you can make a better choice for your future.

Rapid 30 program

The Rapid 30 program is perfect for light loads or when you are in a hurry.

Delay start

Delay the start of the wash program to suit your lifestyle or take advantage of off-peak electricity rates.

Specifications

PRODUCT PROFILE

Domestic warranty details (yrs)	2
---------------------------------	---

Type of Dishwashers	freestanding
---------------------	--------------

Place settings	14
----------------	----

Drying system	residual drying
---------------	-----------------

Number of spray arms	2
----------------------	---

Top shower	No
------------	----

DIMENSIONS

Total height (mm)	845
-------------------	-----

Total width (mm)	598
------------------	-----

Total depth (mm)	600
------------------	-----

SPECIFICATION

Water Efficiency Star Rating	4.5
------------------------------	-----

WELS Registration Number	D02589
--------------------------	--------

Water consumption (litres)	12.5
----------------------------	------

Energy Efficiency Star Rating	3.0
-------------------------------	-----

Energy consumption cold water (kWhr/yr)	320
---	-----

Noise level dBA	52
-----------------	----

Water supply	cold
--------------	------

Basket colour	grey
---------------	------

WASH PROGRAMS

Number of Programs	5
--------------------	---

Programs	glass,intensive,Eco 50°C,fast 30min,Regular 90 min
----------	--

Wash option	Half Load,Extra dry
-------------	---------------------

CONTROL PANEL

Control panel type	Push button electronic
Top mounted control panel	No
Control panel finish	black
Knob or button finish	black
Display indicators	wash program,rinse aid,End,delay start

EXTERIOR

Door finish	black
Side colour	black
Plinth colour (kickboard)	black
Worktop colour	black

LOWER BASKET

Lower Basket Features	cutlery basket
-----------------------	----------------

FEATURES

Other Features	delay start,child lock on control panel
Water safety system	anti-flood protection
Filter system	3 stage
Dispenser	detergent,rinse aid
Number of spray levels	2

UPPER BASKET

Upper basket features	adjustable top basket
Foldable cup shelves	1

HOSES

Drain hose length	160
Inlet hose length (metres)	1.5
Drain hose length (metres)	1.4

SHIPPING

Pack Dimensions Height (mm)	885
--------------------------------	-----

Pack Dimension Width (mm)	645
------------------------------	-----

Pack Dimension Depth (mm)	645
------------------------------	-----

STUFFING QUANTITIES

20ft	54
------	----

40ft	108
------	-----

40ft HC	162
---------	-----

Dimensions

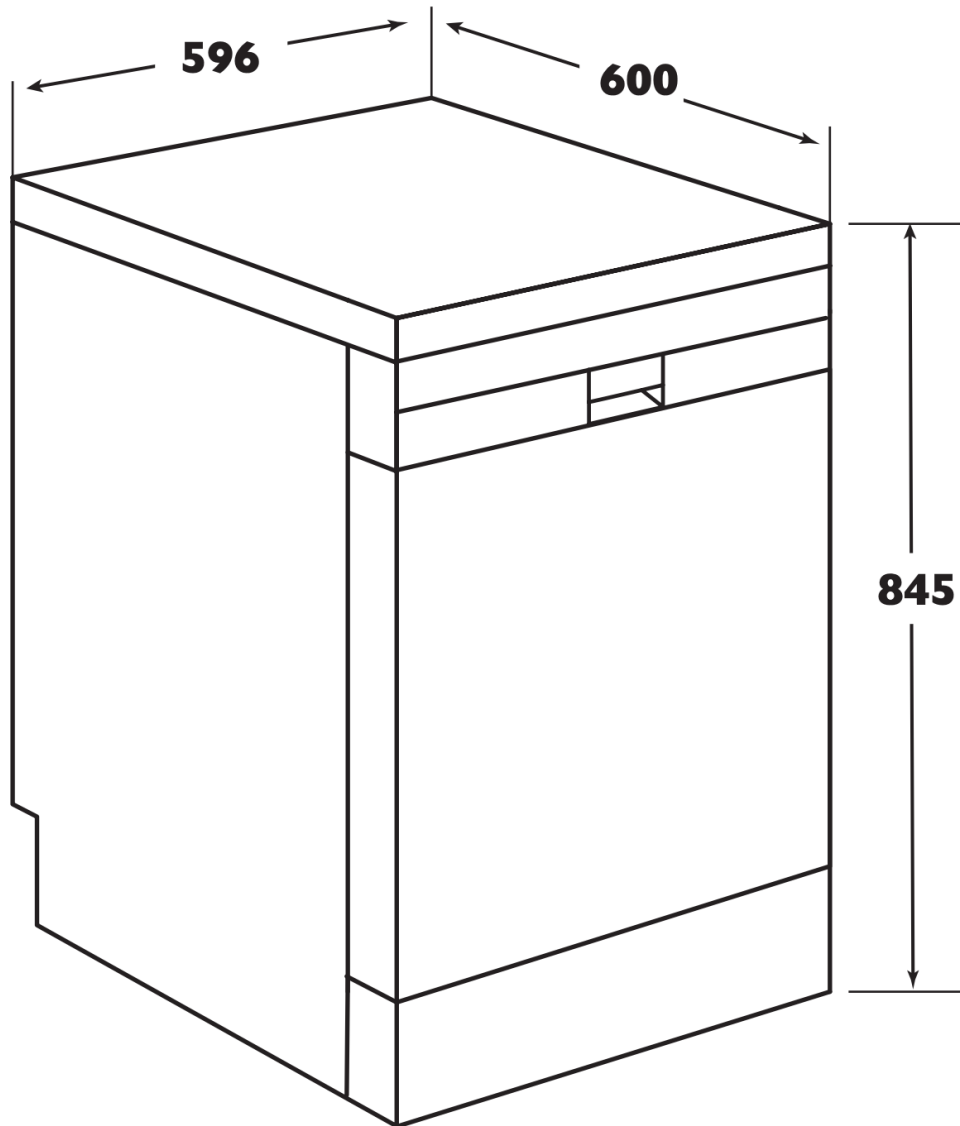

IMPORTANT

These dimensions are a guide only. All measurements are in millimetres (mm).
For complete installation instructions, refer to the manual provided with product.

Terms and Conditions

IMPORTANT

This is a guide of product dimensions only. For complete installation instructions, refer to the manual provided with product.

PRODUCT INFORMATION

The descriptors and illustrations in this publication apply to the specific products and models described as at the date of issue. Under our policy of continuous product development, product specifications may change without notice. Prospective purchasers should therefore check with their retailer to ensure this publication correctly describes the products that are being offered for sale. All information supplied is to be used for general reference purposes only and is on the understanding that Electrolux Home Products Pty Ltd (Australia) and Electrolux (NZ) Ltd (New Zealand) will not be liable for any loss, liability or damage of whatever kind arising as a result of reliance on such information. Colours of products illustrated are as close as printing limitations allow. Electrolux will at all times comply with its obligations pursuant to law including Trade Practices (Australian Consumer Law) Act and Regulations.

WARRANTY

This warranty only applies to Appliances purchased and used in Australia or New Zealand and used in normal domestic applications and is in addition to (and does not exclude, restrict, or modify in any way) any non-excludable statutory warranties in Australia or New Zealand. All warranties are subject to the conditions set out in the warranty card accompanying the product when purchased.

ELECTROLUX HOME PRODUCTS AUSTRALIA

telephone: 1300 363 640

fax: 1800 350 067

email: customercare@electrolux.com.au

web: www.electrolux.com.au

ELECTROLUX HOME PRODUCTS NEW ZEALAND

telephone: 09 573 2230

fax: 09 573 2221

email: customercare@electrolux.co.nz

web: www.electrolux.co.nz