

90cm 5 burner gas cooktop in stainless steel with 14.4 MJ/h wok burner, cast iron trivets, electronic ignition, and flame failure safety.

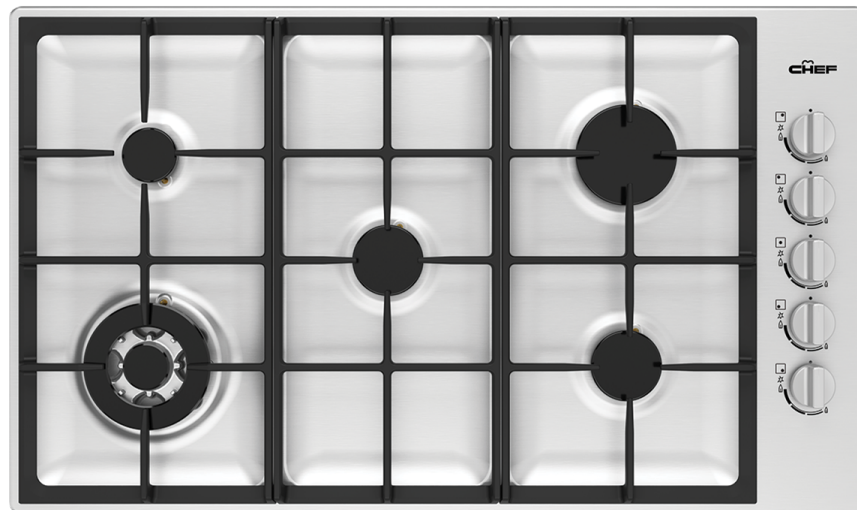

Product Details

FEATURES

High powered 14.4MJ/h wok burner

Heavy-duty cast-iron trivets

One push start ignition

Stylish and functional knobs

Side controls for easy access and safety

Flame failure feature
A safety mechanism that stops the gas flow if the flame is extinguished

Simple and durable control panel graphics

Stylish stainless steel finish

LP Gas Conversion kit included
LP Gas Conversion kit included. Must be installed by a licenced tradesperson.

BENEFITS

High powered wok burner
This high-powered wok burner means that you finally get the heat you need to cook delicious and nutritious stir fry at home.

Cast iron trivets
Our cast iron trivets have been designed to keep your pots and pans stable, as well as being easy to move around between burners.

Push and go. Easy.
One push start ignition, first time, every time.

Side controls for easy access
Side cooktop controls that are easy to use and positioned for safety, so you never have to reach over hot pots and pans again.

Flame Failure for kitchen safety
Designed for extra kitchen safety, the Flame Failure feature will automatically shut off the gas supply if the flame is unexpectedly extinguished.

Easy to maintain
Easy clean formed hob in a stainless steel finish makes this hob easy to maintain

Specifications

PRODUCT PROFILE

Domestic warranty details (yrs)	2
Cooktop type	gas
Materials/Colour	stainless steel
Knob Finish	silver

CONTROLS

Controls of Cooktops	knob
Position of controls	right hand side
Features of Cooktop	flame failure,Cast iron trivets

ELEMENTS/BURNERS

LEFT FRONT ZONE

Left front zone	triple ring wok
-----------------	-----------------

DIMENSIONS

Total product height (mm)	55
Total product width (mm)	860
Total product depth (mm)	510
Cut out width (mm)	830
Cut out depth (mm)	470

FEATURES

Trivets	cast iron
Ignition type	electronic

LEFT REAR ZONE

Left rear zone	simmer
----------------	--------

CENTRE FRONT ZONE

Centre front zone	semi-rapid
-------------------	------------

RIGHT FRONT ZONE

Right front zone	semi-rapid
------------------	------------

RIGHT REAR ZONE

Right rear zone	rapid
-----------------	-------

ELECTRICAL SPECIFICATIONS

Connected load KW	0.05
-------------------	------

Type of connection	10A plug & lead
--------------------	-----------------

GAS SPECIFICATIONS

Total burner output(NG)	49.6
-------------------------	------

Position of gas connection	rear right
----------------------------	------------

SHIPPING

Shipping Volume (m3)	0.095
----------------------	-------

Shipping Weight (Kg)	17.5
----------------------	------

Pack Dimensions Height (mm)	165
-----------------------------	-----

Pack Dimension Width (mm)	966
---------------------------	-----

Pack Dimension Depth (mm)	596
---------------------------	-----

STUFFING QUANTITIES

20ft	280
------	-----

STUFFING QUANTITIES

40ft HC

630

Dimensions

IMPORTANT These dimensions are a guide only. All measurements are in millimetres (mm). For complete installation instructions, refer to the manual provided with product.

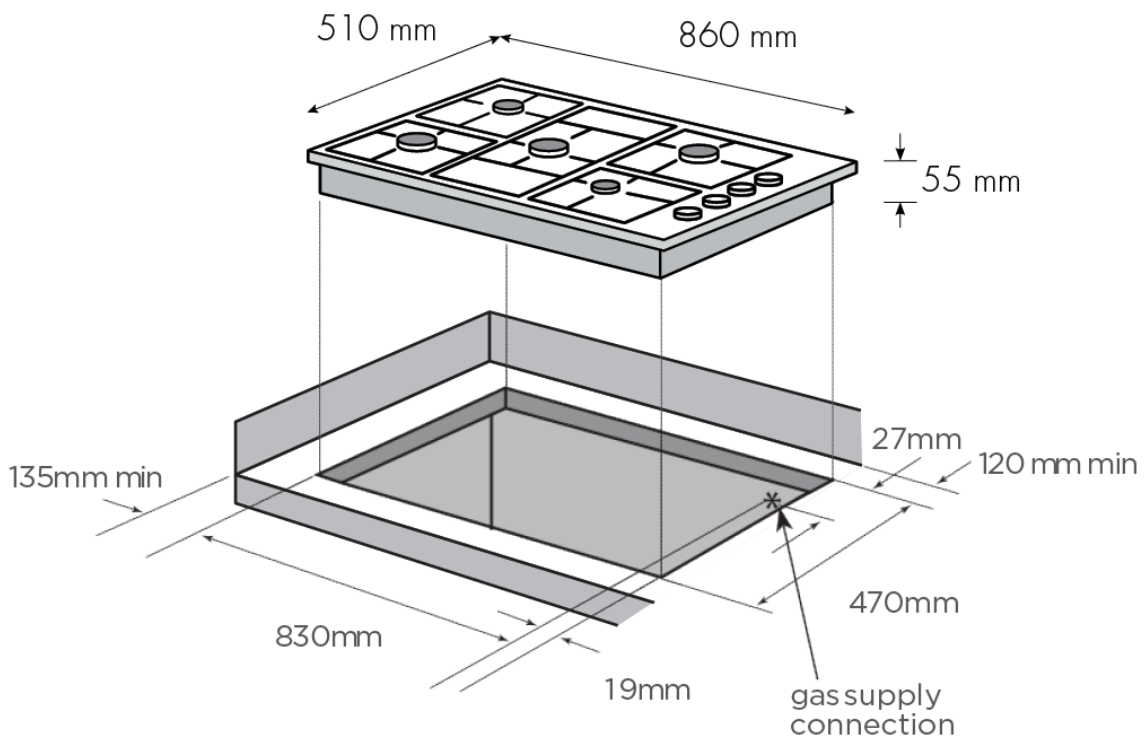

Terms and Conditions

IMPORTANT

This is a guide of product dimensions only. For complete installation instructions, refer to the manual provided with product.

PRODUCT INFORMATION

The descriptors and illustrations in this publication apply to the specific products and models described as at the date of issue. Under our policy of continuous product development, product specifications may change without notice. Prospective purchasers should therefore check with their retailer to ensure this publication correctly describes the products that are being offered for sale. All information supplied is to be used for general reference purposes only and is on the understanding that Electrolux Home Products Pty Ltd (Australia) and Electrolux (NZ) Ltd (New Zealand) will not be liable for any loss, liability or damage of whatever kind arising as a result of reliance on such information. Colours of products illustrated are as close as printing limitations allow. Electrolux will at all times comply with its obligations pursuant to law including Trade Practices (Australian Consumer Law) Act and Regulations.

WARRANTY

This warranty only applies to Appliances purchased and used in Australia or New Zealand and used in normal domestic applications and is in addition to (and does not exclude, restrict, or modify in any way) any non-excludable statutory warranties in Australia or New Zealand. All warranties are subject to the conditions set out in the warranty card accompanying the product when purchased.

ELECTROLUX HOME PRODUCTS AUSTRALIA

telephone: 1300 363 640

fax: 1800 350 067

email: customercare@electrolux.com.au

web: www.electrolux.com.au

ELECTROLUX HOME PRODUCTS NEW ZEALAND

telephone: 09 573 2230

fax: 09 573 2221

email: customercare@electrolux.co.nz

web: www.electrolux.co.nz