

120cm ceiling rangehood with Hob2Hood, remote control, and LED lighting.



Product Details

FEATURES

Dimmer-controlled LED lights

Fully variable fan speed
Including an intensive speed

Metal fan assembly and
blades

Electronic controls

Twin stainless steel mesh
filters

BENEFITS

High Performance Perimeter Extraction

Higher speed air extraction is created by drawing the same volume of air through a smaller vent. Same volume, faster velocity. 730cm/h extraction speed vs 690cm/h.

Dimmer-controlled LED lights

Dimmer-controlled LED lighting means you can adjust the effect at the touch of a fingertip. Being highly efficient, LED lights save on energy too.

Metal fan

The fan provides effective clearing of all vapours and smoke generated during cooking through an efficient filtration system. The stainless steel mesh filter is easily cleaned in a standard dishwasher cycle. The rangehood comes with a remote control.

Filter light

The rangehood has a filter saturation sensor that will illuminate the light on the control panel to inform the user when cleaning is recommended.

Specifications

PRODUCT PROFILE

Domestic warranty details (yrs)	5
Type of Rangehood	integrated
Design family (eline)	Mastery Range
Nominal width (cm)	120
Finish of Rangehood	mark resistant stainless steel

DIMENSIONS

Total product height (mm)	311
Total product width (mm)	1200

MOTOR/FAN

Number of fans	1
Number of fans speeds	4
Variable speed control	Yes
Auto off	Yes
Type of motor	single motor
Auto fan timer	Yes
Maximum airflow M3/Hr	710
Noise level dB high	70
Noise level dB low	54
Wattage of motor	270

POWER

Electricity supply required (Kw)	60.6
Connection plug	10

DIMENSIONS

Total product depth (mm)	500
Diameter of ducting (mm)	150
Minimum installation height from cooking surface Gas (mm)	650
Minimum installation height from cooking surface Electric (mm)	650

CONTROLS

Control panel	electronic push button
Safety/ display indicators	auto thermal cutout safety switch, clean filter indicator, automatic safety cut off, grease filter saturation indicator
LED speed display	Yes

LIGHTS

Number of lights	4
Wattage of light	40
Type of light	dimmer-controlled LED light

FILTERS

Number of filters	4
Type of filter	aluminum micromesh
Dishwasher safe	Yes

DUCTING / RECIRCULATION

Ducting	yes
Top or rear duct hole	top
Recirculation option	Yes

DUCTING / RECIRCULATION

Type of filter	Carbon
----------------	--------

Number of optional filters required	two
-------------------------------------	-----

SHIPPING

Shipping Volume (m3)	0.236
----------------------	-------

Shipping Weight (Kg)	23.5
----------------------	------

Product Weight (Kg)	17.0
---------------------	------

Pack Dimensions Height (mm)	620
-----------------------------	-----

Pack Dimension Width (mm)	360
---------------------------	-----

Pack Dimension Depth (mm)	1060
---------------------------	------

Dimensions

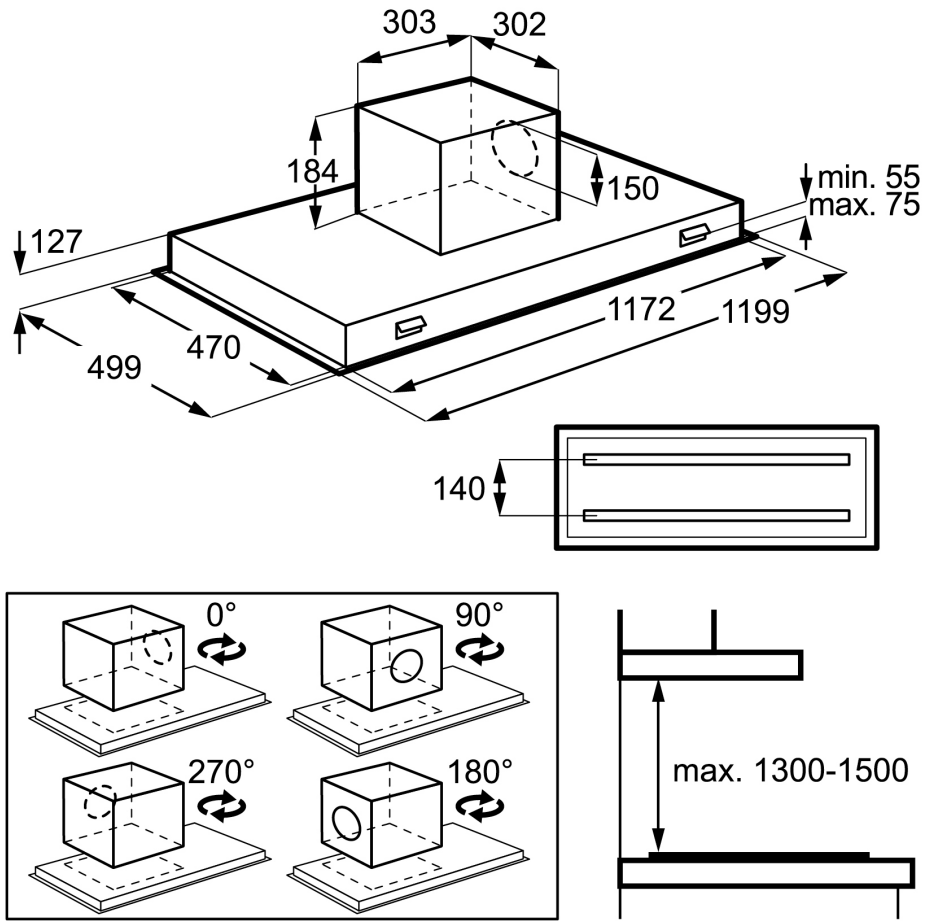

IMPORTANT

These dimensions are a guide only. All measurements are in millimetres (mm).
 For complete installation instructions, refer to the manual provided with product.

Terms and Conditions

IMPORTANT

This is a guide of product dimensions only. For complete installation instructions, refer to the manual provided with product.

PRODUCT INFORMATION

The descriptors and illustrations in this publication apply to the specific products and models described as at the date of issue. Under our policy of continuous product development, product specifications may change without notice. Prospective purchasers should therefore check with their retailer to ensure this publication correctly describes the products that are being offered for sale. All information supplied is to be used for general reference purposes only and is on the understanding that Electrolux Home Products Pty Ltd (Australia) and Electrolux (NZ) Ltd (New Zealand) will not be liable for any loss, liability or damage of whatever kind arising as a result of reliance on such information. Colours of products illustrated are as close as printing limitations allow. Electrolux will at all times comply with its obligations pursuant to law including Trade Practices (Australian Consumer Law) Act and Regulations.

WARRANTY

Electrolux Home Products warrants that for domestic applications the AEG appliances featured are free from defects in materials and workmanship for 5 years (3 months warranty for commercial applications). All warranties are subject to the conditions set out in the warranty card accompanying the product when purchased.

ELECTROLUX HOME PRODUCTS AUSTRALIA

telephone: 1300 363 664

fax: 1800 350 067

email: customercare@aegaustralia.com.au

web: www.aeg.com/au

ELECTROLUX HOME PRODUCTS NEW ZEALAND

telephone: 0800 10 66 10

fax: 09 573 2221

email: customercare@electrolux.co.nz

web: www.aeg.com/au