

Commercial exclusive model. 60cm 7 function SteamBake oven with programmable timer and double glazed door.



## Product Details

### FEATURES

---

MaxiView™ enlarged window

IsoFront™ - A genuine cooler door

FloodLight™ system

Anti-fingerprint stainless steel

---

### BENEFITS

---

#### Add steam for crispier baking

The SteamBake button in this oven adds steam at the beginning of the baking process. The steam cooking keeps the dough moist on the surface to create a golden colour and tasty crust, while the centre stays soft and tender. In addition to baking crispy and tasty breads, muffins and pies - your roast chicken, grilled meats and lasagne will get equally delicious cooking results.

#### Multi-function Oven

This multi-function oven offers both fan forced and conventional cooking options, so you can get the best results from whatever you're cooking.

---

## Specifications

### PRODUCT PROFILE

Domestic warranty details (yrs)	5
Type of Oven	single oven
Oven fuel	electric
Materials/Colour	anti-fingerprint stainless
Controls of Oven	retractable control knobs
Cooling fan	Yes

### FLUSH FIT CUT OUT

Flush fit cut out height (mm)	600
Flush fit cut out width (mm)	560
Flush fit cut out depth (mm)	550

### DIMENSIONS

#### PRODUCT DIMENSION

Total height (mm)	589
Total width (mm)	594
Total depth (mm)	569

### MAIN OVEN

Useable capacity litres	72
Oven function	multifunction
Number of functions	7
Oven Functions	defrost,light,true fan cooking,grilling,turbo grilling,moist fan baking,fast grilling

## SECOND OVEN OR GRILL

Closed door grilling	Yes
----------------------	-----

## OTHER FEATURES

Door	removable door
Timer	Programmable timer
Lights	1
Light wattage	40
Light position	rear

## MAIN OVEN

Timer functions	acoustic signal,duration,end,minute minder,Time of day
Light wattage	40

## ELECTRICAL CONNECTION

Connected load KW	2.78
Maximum current rating (amps)	12
Type of connection	hardwired
Minimum Fuse rating (amps)	16

## SHIPPING

Shipping Volume (m3)	0.278
Shipping Weight (Kg)	28.5
Pack Dimensions Height (mm)	654
Pack Dimension Width (mm)	635

## OTHER FEATURES

---

Shelf support	multi position side racks
Number of shelves	2
Closed door grilling	Yes
Included accessories	black enamel dripping pan,2 x chromed wire shelf,trivet
Layers of glass in door	2
Number of shelf positions	5

## SHIPPING

---

Pack Dimension Depth (mm)	670
---------------------------	-----

---

## Dimensions

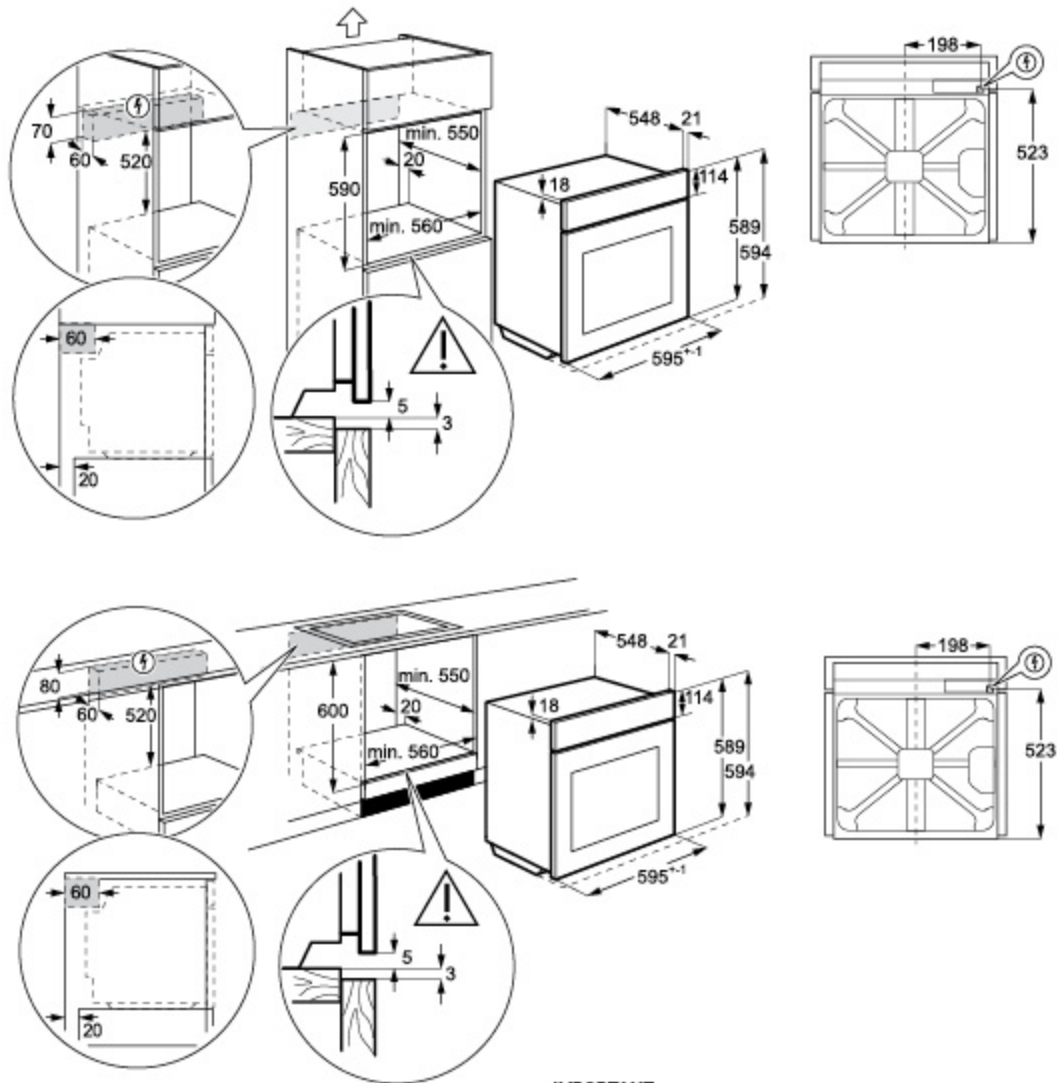

### IMPORTANT

These dimensions are a guide only. All measurements are in millimetres (mm).

For complete installation instructions, refer to the manual provided with product.

## Terms and Conditions

### IMPORTANT

This is a guide of product dimensions only. For complete installation instructions, refer to the manual provided with product.

### PRODUCT INFORMATION

The descriptors and illustrations in this publication apply to the specific products and models described as at the date of issue. Under our policy of continuous product development, product specifications may change without notice. Prospective purchasers should therefore check with their retailer to ensure this publication correctly describes the products that are being offered for sale. All information supplied is to be used for general reference purposes only and is on the understanding that Electrolux Home Products Pty Ltd (Australia) and Electrolux (NZ) Ltd (New Zealand) will not be liable for any loss, liability or damage of whatever kind arising as a result of reliance on such information. Colours of products illustrated are as close as printing limitations allow. Electrolux will at all times comply with its obligations pursuant to law including Trade Practices (Australian Consumer Law) Act and Regulations.

### WARRANTY

This warranty only applies to Appliances purchased and used in Australia or New Zealand and used in normal domestic applications and is in addition to (and does not exclude, restrict, or modify in any way) any non-excludable statutory warranties in Australia or New Zealand. All warranties are subject to the conditions set out in the warranty card accompanying the product when purchased.

#### ELECTROLUX HOME PRODUCTS AUSTRALIA

telephone: 1300 363 640

fax: 1800 350 067

email: [customercare@electrolux.com.au](mailto:customercare@electrolux.com.au)

web: [www.electrolux.com.au](http://www.electrolux.com.au)

#### ELECTROLUX HOME PRODUCTS NEW ZEALAND

telephone: 09 573 2230

fax: 09 573 2221

email: [customercare@electrolux.co.nz](mailto:customercare@electrolux.co.nz)

web: [www.electrolux.co.nz](http://www.electrolux.co.nz)